

NOTES:

1. TERMINAL TO BE USED IN HOUSINGS 70066-**** AND 70450-****
2. REFER TO PRODUCT SPECIFICATION PS-71851
3. REFER TO MOLEX OPERATIONS AND SERVICE MANUAL FOR CRIMP DETAILS
4. TERMINAL TO BE USED WITH (0.64)/.025 SQUARE PINS
5. TERMINAL TO BE USED WITH 22-24 AWG STRANDED WIRE WITH (1.63)/.064 MAX. DIA. INSULATION
6. TERMINALS SUPPLIED IN REEL FORM

PLATING:

.000015 MINIMUM GOLD PLATE IN SELECT AREA WITH .000075 MINIMUM TIN PLATE IN SELECT AREA OVER NICKEL PLATE OVERALL

*THE PRIMARY SHIPPING CARTON WILL BE LABELED "COMPLIANT TO RoHS DIRECTIVE 2002/95/EC AND ELV ANNEX II OF DIRECTIVE 2000/53/EC". CARTONS WITHOUT THIS LABEL MAY CONTAIN PRODUCT WITH LEAD.

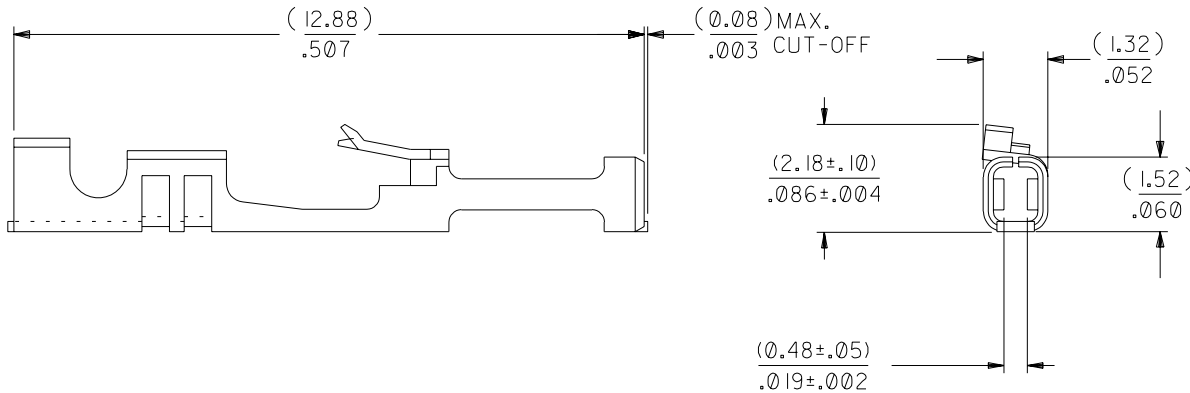
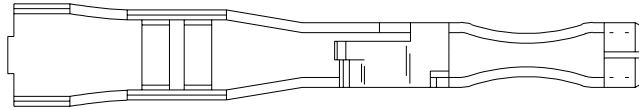

				B		REVISE PER ECR# U82219 11-07-88 MJM/MGB		DIMENSIONS SHOWN (METRIC) INCH UNLESS OTHERWISE SPECIFIED TOLERANCES: ANGULAR ± 1/2°		▽ = 0 ▼ = 0 REVISE ONLY ON CAD SYSTEM																				
		C		A		FINAL RELEASE PER ERO #26846 7/14/88 MJM		<table border="1"> <thead> <tr> <th></th> <th>INCH</th> <th>METRIC</th> </tr> </thead> <tbody> <tr> <td>3 PLACE</td> <td>± .010</td> <td>---</td> </tr> <tr> <td>2 PLACE</td> <td>± .014</td> <td>± 0.25</td> </tr> <tr> <td>1 PLACE</td> <td>---</td> <td>± 0.35</td> </tr> </tbody> </table>			INCH	METRIC	3 PLACE	± .010	---	2 PLACE	± .014	± 0.25	1 PLACE	---	± 0.35	TITLE TERMINAL-BOX/CRIMP HIGH FORCE CONTACT								
	INCH	METRIC																												
3 PLACE	± .010	---																												
2 PLACE	± .014	± 0.25																												
1 PLACE	---	± 0.35																												
		BI		3		REVISED ECR #U80270 MCGRATH 97/07/31		DRAFT WHERE APPLICABLE MUST REMAIN WITHIN DIMENSIONS		<table border="1"> <tr> <td rowspan="2">moLEX</td> <td colspan="2">MOLEX INCORPORATED</td> <td>SHEET NO.</td> <td>DATE</td> </tr> <tr> <td>LISLE,ILL.</td> <td>60532</td> <td>U.S.A.</td> <td>03/25/88</td> </tr> <tr> <td colspan="2">PART NO.</td> <td colspan="2">DRWG. NO.</td> <td></td> </tr> <tr> <td colspan="2">016-02-1124</td> <td colspan="2">SD-71851-0024</td> <td></td> </tr> </table>		moLEX	MOLEX INCORPORATED		SHEET NO.	DATE	LISLE,ILL.	60532	U.S.A.	03/25/88	PART NO.		DRWG. NO.			016-02-1124		SD-71851-0024		
moLEX	MOLEX INCORPORATED		SHEET NO.	DATE																										
	LISLE,ILL.	60532	U.S.A.	03/25/88																										
PART NO.		DRWG. NO.																												
016-02-1124		SD-71851-0024																												
		LTR.		LTR.		REVISIONS		<table border="1"> <tr> <td>DRWG. BY</td> <td>MJM</td> <td>CHK'D. BY</td> <td>MJM</td> </tr> <tr> <td>APP'D. BY</td> <td>WAZ</td> <td>SCALE</td> <td>10:1</td> </tr> </table>		DRWG. BY	MJM	CHK'D. BY	MJM	APP'D. BY	WAZ	SCALE	10:1	<table border="1"> <tr> <td>FILE NAME</td> <td>DIV.</td> <td>SIZE</td> </tr> <tr> <td>S71851X5</td> <td>DA</td> <td>B</td> </tr> </table>		FILE NAME	DIV.	SIZE	S71851X5	DA	B					
DRWG. BY	MJM	CHK'D. BY	MJM																											
APP'D. BY	WAZ	SCALE	10:1																											
FILE NAME	DIV.	SIZE																												
S71851X5	DA	B																												
										THIS DRAWING CONTAINS INFORMATION THAT IS PROPRIETARY TO MOLEX INC. AND SHOULD NOT BE USED WITHOUT WRITTEN PERMISSION.																				